

SI-2010

Die Grinder

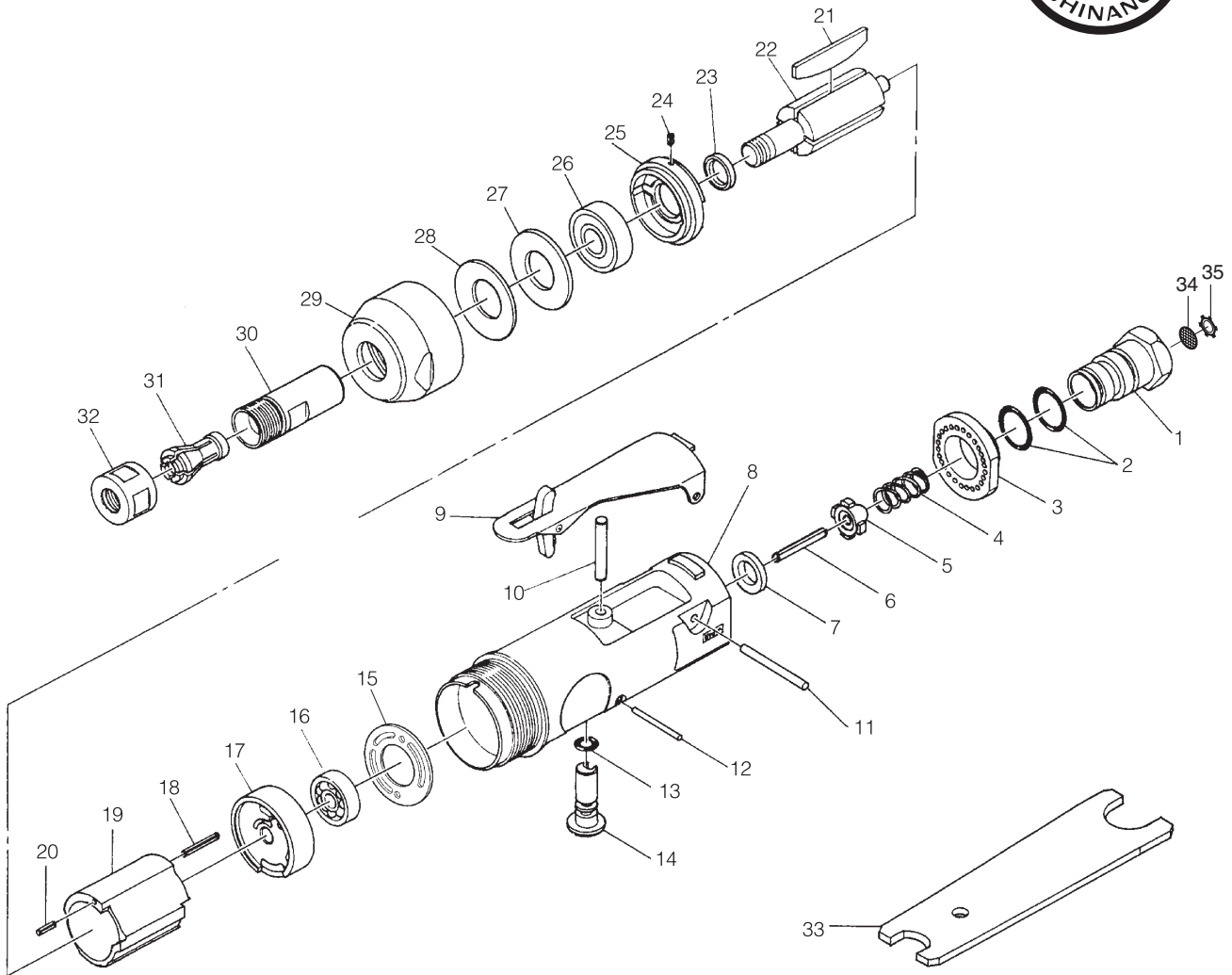

Ref. No.	Parts No.	Description	Q'ty	Ref. No.	Parts No.	Description	Q'ty
1	1400-7	Inlet Bushing	1	19	1400-14	Cylinder	1
2	S-15	O-Ring	2	20	15-8	Roll Pin (1.5ø-8mm)	1
3	1400-8	Deflector	1	21	670-15	Rotor Blade	4
4	1400-13	Valve Spring	1	22	1400-2	Rotor	1
5	960-35	Valve	1	23	350-18	Collar	1
6	30-25	Roll Pin (3ø-25mm)	1	24	25-4	Roll Pin (2.5ø-4mm)	1
7	960-34	Valve Seat	1	25	1400-3	Front Plate	1
8	1400-1	Motor Housing	1	26	6000-ZZ	Ball Bearing	1
9	1400-5A	Throttle Lever	1	27	1400-15	Washer	1
10	190-33	Valve Pin	1	28	DWB-1600	Belleville Washer	1
11	1400-11	Lever Pin	1	29	1400-6	Lock Nut	1
12	200-31	Pin	1	30	350-22	Spindle	1
13	P-4	O-Ring	1	31	330-19	6mm Collet	1
14	1400-9	Air Regulator	1	32	350-23	Collet Nut	1
15	1400-10	Gasket	1	33	350-28	Spanner Wrench (11x17mm)	2
16	626	Ball Bearing	1	34	680-28A	Screen	1
17	1400-4	Rotor Plate	1	35	CRTW-12	Retainer	1
18	15-18	Roll Pin (1.5ø-18mm)	1				