

# SI-1420T

1/2" Sq. Dr. Twin Hammer Impact Wrench

# SI-1422T

1/2" Sq. Dr. Twin Hammer Impact Wrench

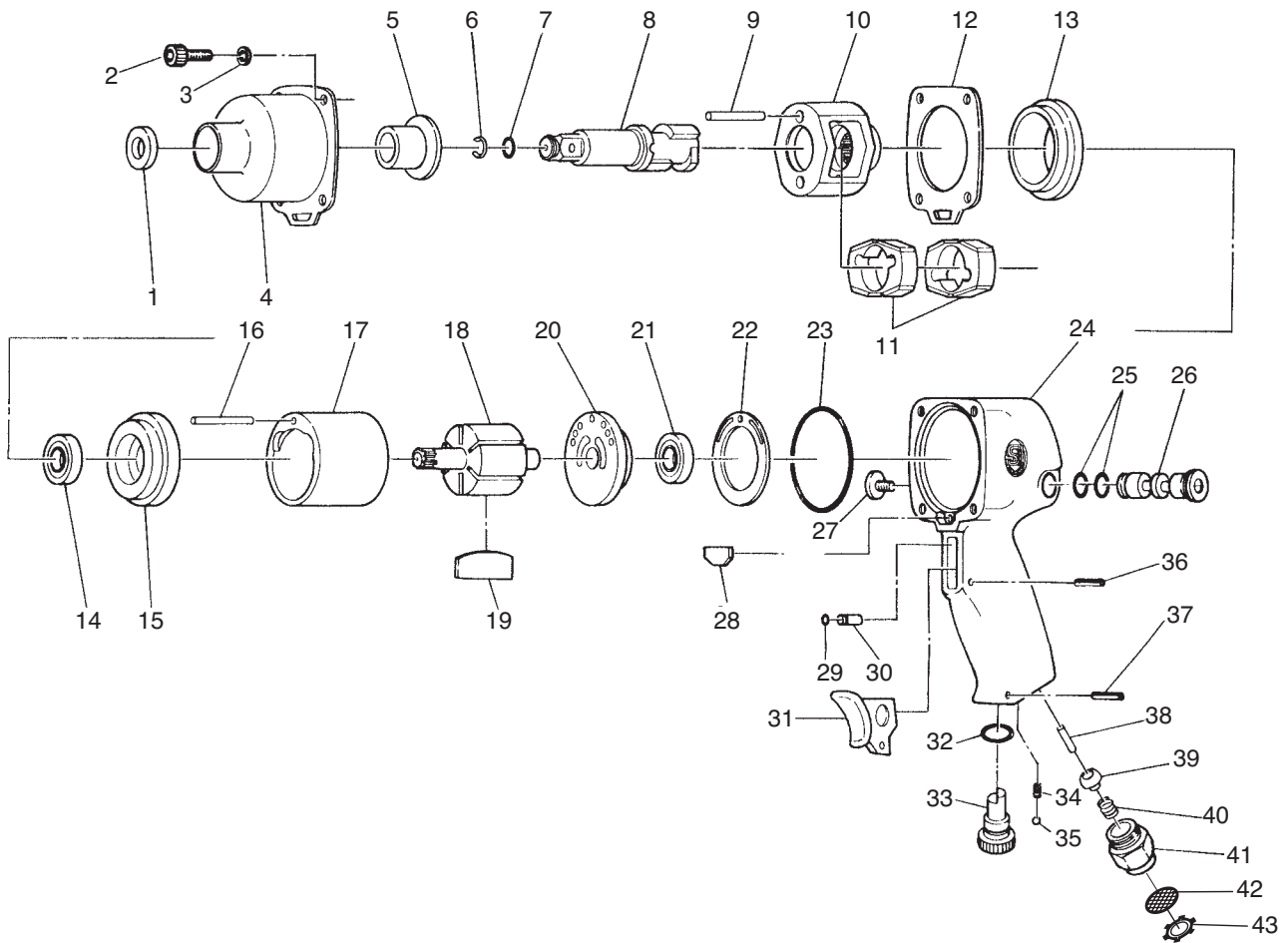

Ref. No.	Parts No.	Description	Q'ty	Ref. No.	Parts No.	Description	Q'ty
1	910-18	Oil Seal	1	23	930B-15	O-Ring	1
2	Z-1024-180	Cap Screw	4	24	930-1S1	Motor Housing incl. Bushes & Steel Ball (445-46, 930-9, SB-8)	1
3	HSW-50	Washer	4	25	930-52	O-Ring	2
4	935AT-1	Hammer Housing incl. Bush & Oil Seal (910-18, 935AT-2)	1	26	930-7	Reverse Valve	1
5	935AT-2	Anvil Bushing	1	27	930-8	Reverse Valve Screw	1
6	930-48	Socket Retainer Ring	1	28	930-20	Deflector	1
7	P-7	O-Ring	1	29	440-26	Push Pin O-Ring	1
8	935AT-4	1/2" Sq. Anvil	1	30	440-18	Push Pin	1
9	935AT-6	Hammer Pin	2	31	930B-10	Trigger	1
10	935AT-3	Hammer Cage	1	32	P-12	O-Ring	1
11	935AT-5	Hammer Dog	2	33	930-10	Air Regulator	1
12	930-45	Hammer Housing Gasket	1	34	450-45	Spring	1
13	930-22	Hammer Cage Spacer	1	35	SB-1/8	Steel Ball	1
14	6202	Ball Bearing	1	36	30-18	Roll Pin (3-18mm)	1
15	930B-4	Front Plate	1	37	30-20	Roll Pin (3-20mm)	1
16	910-21	Motor Pin	1	38	930-12	Valve Pin	1
17	930B-1	Cylinder	1	39	930B-12B	Valve	1
18	930B-2	Rotor	1	40	440-33	Valve Spring	1
19	911A-18	Rotor Blade	6	41	990-26-5	Inlet Bushing	1
20	930B-5	Rear Plate	1	42	680-28A	Screen	1
21	6201	Ball Bearing	1	43	CRTW-12	Retainer	1
22	930-15	Motor Gasket	1	★ 44	935AT-4L	1/2" Sq. Long Anvil	1