

# SI-3105A(M) 5" Dual Action Sander

# SI-3105-6A(M) 6" Dual Action Sander

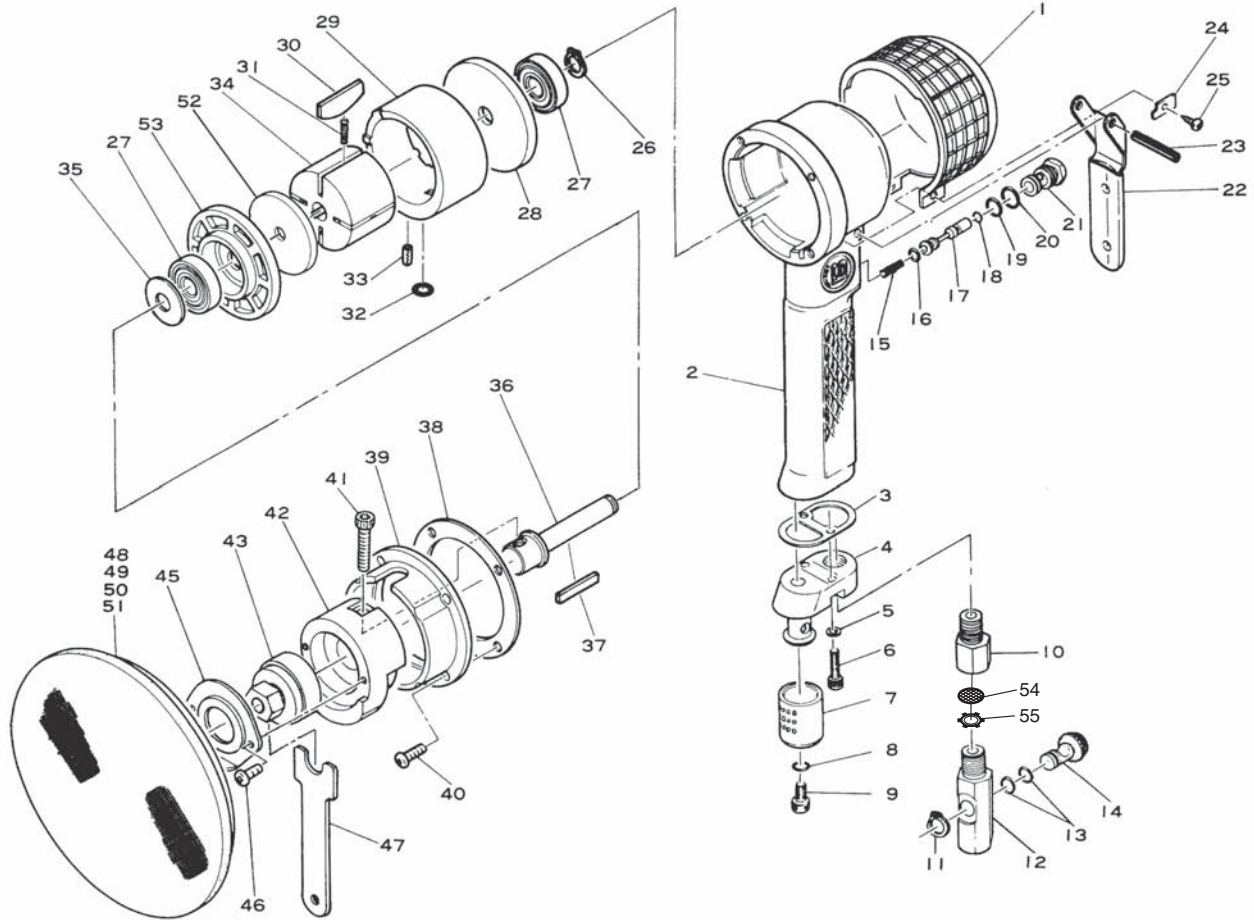

Ref. No.	Parts No.	Description	Q'ty	Ref. No.	Parts No.	Description	Q'ty
1	482-29	Housing Cover	1	29	482-39	Cylinder	1
2	482-3	Motor Housing	1	30	470-9	Rotor Blade	4
3	482-43	Gasket	1	31	490-1	Blade Spring	2
4	482-44	Housing Cap	1	32	P-7	O-Ring	1
5	HSW-40	Washer	2	33	30-6	Roll Pin (3ø-6mm)	1
6	Z-832--160	Cap Screw	2	34	482-6TS	Rotor	1
7	266-39	Deflector	1	35	481-10	Spacer (Brass)	1
8	P-6	O-Ring	1	36	482-15	Crank Shaft	1
9	Z-M60--100	Cap Screw	1	37	482-16	Key	1
10	680-18	Inlet Bushing	1	38	470-49	Gasket	1
11	JS-9	Retaining Ring	1	39	481-47	Balancer Cover	1
12	482-7	Inlet Bushing	1	40	A-M50--120	Screw	4
13	P-5	O-Ring	2	41	Z-M60--250	Cap Screw	1
14	170-17	Air Regulator	1	42	482-31	Balancer	1
15	482-46	Valve Spring	1	43	485A-10	Random Shaft incl. Bearing & Felt Ring (6202-ZZ, 485A-11)	1
16	P-4	O-Ring	1	45	485A-12	Bearing Retainer	1
17	485-1A	Valve Stem	1	46	A-M50--80	Screw	2
18	P-3	O-Ring	1	47	485A-13	Spanner Wrench (19mm)	1
19	P-8	O-Ring	1	☆ 48	PE-125H	5" Leather Pad	1
20	S-10	O-Ring	1	☆ 49	ME-125H	5" Velcro Pad	1
21	485-5	Valve Body	1	★ 50	P-150H	6" Leather Pad	1
22	480-13A	Throttle Lever	1	★ 51	M-150H	6" Velcro Pad	1
23	40-30	Roll Pin (4ø-30mm)	1	52	640-19	Bearing Case Cover	1
24	482-45	Retainer	2	53	482K-1	Bearing Case	1
25	JBM40---80	Screw	2	54	680-28A	Screen	1
26	JS-10	Retaining Ring	1	55	CRTW-12	Retainer	1
27	6200-ZZ	Ball Bearing	2				
28	640-18	End Plate	1				