

SI-3118A(M) 5" Dual Action Sander (Dust Free)

SI-3118-6A(M) 6" Dual Action Sander (Dust Free)

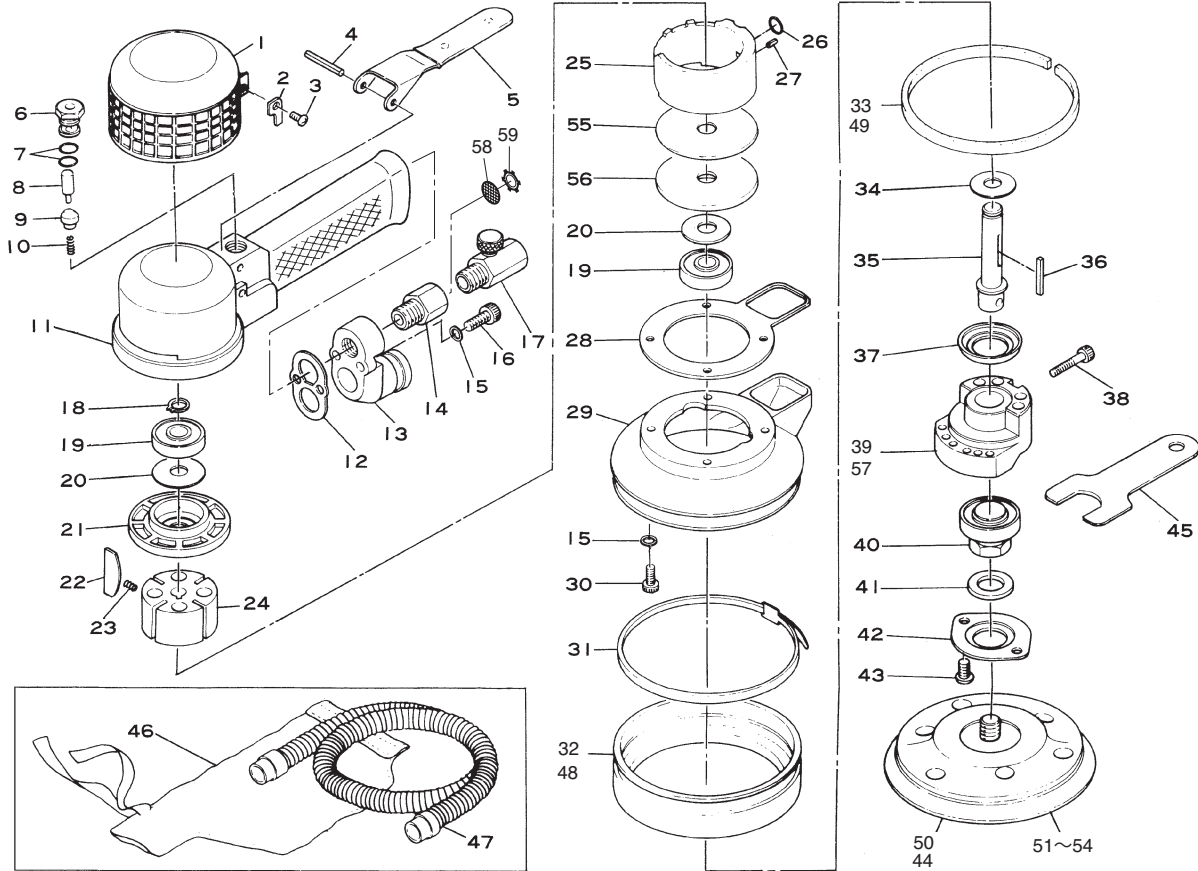

Ref. No.	Parts No.	Description	Q'ty	Ref. No.	Parts No.	Description	Q'ty
1	485A-2	Housing Cover	1	31	485A-44	Band	1
2	482-45	Retainer	1	32	485A-9	Pad Cover for 5" Pad	1
3	JBM40---80	Screw	2	33	491DF-1	Felt Ring	1
4	40-30	Roll Pin (4ø-30mm)	1	34	485-10	Bearing Seal	1
5	480-13A	Throttle Lever	1	35	482-15	Crank Shaft	1
6	490-4	Valve Body	1	36	482-16	Key	1
7	S-10	O-Ring	2	37	481-9	Seal Cover	1
8	455-11	Valve Pin	1	38	Z-M60--250	Cap Screw	1
9	455-21	Valve	1	39	482-31	Balancer	1
10	490-20	Valve Spring	1	40	485A-10	Random Shaft incl. Bearing & Felt Ring (6202-ZZ, 485A-11)	1
11	485A-1	Motor Housing	1	42	485A-12	Bearing Retainer	1
12	485A-4	Gasket	1	43	A-M50---80	Screw	2
13	485A-3	Housing Cap	1	44	ME-125HD	5" Velcro Pad	1
14	680-18	Inlet Bushing	1	45	485A-13	Spanner Wrench (19mm)	1
15	HSW-50	Washer	6	46	485-42	Dust Pack	1
16	Z-M50--150	Cap Screw	2	47	570-42	Dust Hose	1
17	181-45	Air Regulator	1	48	485A-7	Pad Cover for 6" Pad	1
18	IS-10	Retaining Ring	1	★ 49	485A-8	Felt Ring for 6"	1
19	6200-ZZ	Ball Bearing	2	★ 50	PE-125HD	5" Leather Pad	1
20	485-45	Seal	2	★ 51	M-150HD 6	6" Velcro Pad	1
21	640-18	End Plate	1	★ 52	P-150HD 6	6" Leather Pad	1
22	470-9	Rotor Blade	4	★ 53	M-150HD 9	6" Velcro Pad	1
23	490-1	Blade Spring	2	★ 54	P-150HD 9	6" Leather Pad	1
24	482-6TS	Rotor	1	55	640-19	Bearing Case Spacer	1
25	482-39	Cylinder	1	56	482K-1	Bearing Case	1
26	P-7	O-Ring	1	★ 57	481-13A	Balancer for 6"	1
27	30-6	Roll Pin (3ø-6mm)	1	58	680-28A	Screen	1
28	485A-6	Gasket	1	59	CRTW-12	Retainer	1
29	485A-5	Motor Retainer	1				
30	Z-M50--200	Cap Screw	4				